

ЛД-16 ИИ

**Federal State Budgetary Educational Institution of Higher Education
«North-Ossetia State Medical Academy»
of the Ministry of Healthcare of the Russian Federation
(FSBEI HE NOSMA MOH Russia)**

Department of Biology and Histology

WORKBOOK
for practical classes and independent work
“CYTOLOGY, ONTOGENESIS”
of discipline “biology”

the main professional educational program of higher education - specialty program
in the specialty 31.05.01 General Medicine, approved in August 31, 2020

VLADIKAVKAZ, 2020

Authors:

Bibaeva L.V. Professor, Doctor of Medicine, Head of department of Biology and Histology of North Ossetian State Medical Academy.

Tseboeva A.A., senior Lecturer of department of Biology and Histology of North Ossetian State Medical Academy

PRACTICAL CLASS №1

MICROSCOPE. MICROSCOPIC TECHNIQUE

COMPETENCES:

GC-5, GPC-1.

I. THE AIM:

1. To know the structure of light microscope.
2. To acquire the practical knowledge of work with microscope.
3. To acquire the practical knowledge of manufacture the temporary preparations.

II. THE BASIC KNOWLEDGE:

1. Optic laws and motion of light rays through a microscope.

III. THE PLAN FOR THE THEME STUDY:

1. Studying the microscope system.
2. Mastering the principles of work with microscope.
3. Studying the techniques of making temporary preparations.
4. Learning to master microscoping under the low and high power magnification.
5. Mastering the rules of design of laboratory works in the album.

IV. THE SYSTEM OF MICROSCOPE.

The microscope uses the magnifying powers of two convex lenses to produce a magnified image of a very small object. Compound microscope is meant to examine and study small, semitransparent or translucent objects, either entire or in parts, or in thin slices cut out from the object.

The microscope system consists of three main parts:

- mechanical;
- optical;
- lighting.

I. The mechanical part includes:

- 1) support (base (6), arm (3));
- 2) tube (2);
- 3) stage with spring clips and system of screws (9);
- 4) coarse adjustment screw (it serves for raising and lowering the tube and examination of slides under the low power magnification) (4);
- 5) screw for condenser (it serves for raising and lowering of sub-stage condenser) (12);
- 6) fine adjustment screw (it serves for examination slides under high power magnification) (5);
- 7) triple nosepiece (10).

II. Optical part includes:

- 1) eyepiece (ocular) (it is the system of lenses: magnification - x7, x10, x15);(1)
- 2) objectives (these are the system of lenses: low power magnification – x9; high power magnification - x40; oil immersion - x90). (11)

III. Lighting part includes:

- 1) mirror with concave and flat surfaces (7)
- 2) sub-stage condenser (it serves for regulation of light. If you lower down it, the light is decreased. If you raise it, the light is increased) (8).
- 3) iris disc diaphragm (it serves for regulation of light).

V. THE PRINCIPLES OF WORK WITH MICROSCOPE.

Adjustment of the microscope for the work.

1. Clean all lenses and mirror.
2. Raise the sub-stage condenser.
3. Open the iris disk diaphragm.

Adjustment of the microscope for low power work.

1. Examination of any objects is begun under low power magnification (x63).
2. The object on the slide must be illuminated and this can be done with light from a window. Light shines on the under-stage mirror such that the curved surface reflects it up through the hole in the stage.
3. Using the coarse adjustment screw, raise up the tube and turn the nosepiece until the lowest power objective (x9) clicks into line with the microscope tube.
4. The microscope must always be focused upwards, never downwards. It is very easy to pass through the plane of focus when looking through the microscope and focusing downwards and as a result damage the slide.
5. Place the slide to be examined on the microscope stage such that the material under the cover-slip is in the middle of the aperture of the stage.
6. Viewing the stage and the slide from the side, rack down the coarse adjustment until the low power objective is about 5 mm from the slide.
7. Looking through the microscope, rack up by means of the coarse adjustment until the object is in focus (the image is appeared).

Adjustment of the microscope for high power work.

1. Turn the nosepiece until the high power objective lens (x40) clicks into place. If focus has already been achieved under low power, the nosepiece should automatically bring the high power lens into approximate focus. Adjust carefully using the fine adjustment and always focusing upwards.
2. After finishing examination, place objective with low power magnification.

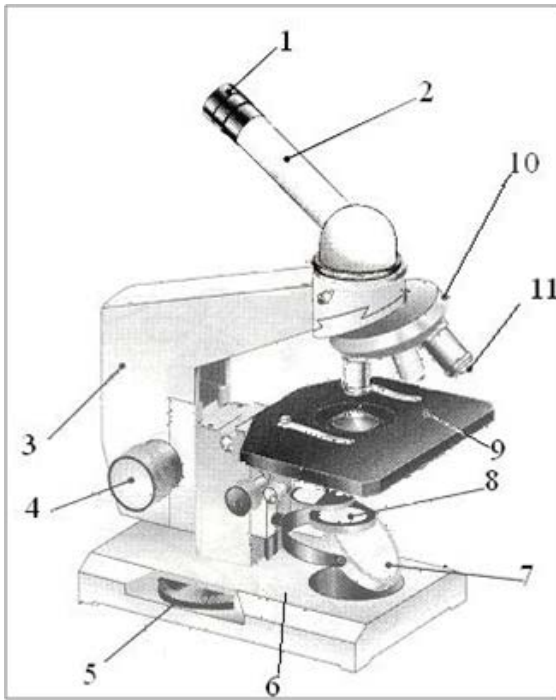

VI. THE RULES OF DESIGN OF ALBUM AND LABORATORY WORKS.

Album is the form of student's report about independent work in the laboratory. All of the objects examined during practical classes must be drawn in the album.

1. Title page:

ALBUM
for practical classes in medical biology
of the first year student
group №
Name

2. Draw the objects, schemes or charts on the right page.
3. Write by pen, draw by pencil and colored pencils.
4. Write the theme of practical class on the top of a page. During study of Parasitology indicate the phylum, class, order, genus and species of parasite in Latin.
5. Indicate the magnification (low power magnification – x63; high power magnification – x280).
6. Under the name of the work and magnification draw the object and indicate its details.
7. Put the arrows to details by pencil, and label it by pen.
8. Under the figure write the names of labels by pen (on the right).
9. The figure must be clear with exact details. There must be 3-4 figures on one page if the objects are simple. If the object is compound and large, draw only one figure on the page.
10. The main demand of figure is correct reflection of form, measures of object, its details and scale.
11. Every practical class album is to be checked and signed by the teacher.

VII. INDEPENDENT WORK IN THE LABORATORY. LABORATORY WORKS.

Make and study of temporary preparation of human hair (x63, x280).

- 1) Take the glass slide, clean it and put the drop of water in the center of slide.
- 2) Take the piece of human hair and put it into the drop of water on the slide.
- 3) Cover the preparation by cover-slip.
- 4) Put the preparation on the stage and look for it under low power magnification.

- 5) Examine the structure of hair. Draw it in the album.
- 6) Look for the preparation under high power magnification and draw it.
(Observe the correlation between the dimension of hair under low and high power magnifications.)
- 7) Take away the slide.

VIII. HOMEWORK: Cell as an elementary unit of living matter.

PRACTICAL CLASS №2
CELL AS AN ELEMENTARY UNIT OF LIVING MATTER

COMPETENCES:
GC-5, GPC-1.

I. THE AIM:

1. To study the morphological organization of an elementary unit of living matter – the cell.
2. To master the practical skills for determination of cell structure.

II. THE BASIC KNOWLEDGE:

1. Characteristics of living matter.
2. Levels of biological organization.

III. THE PLAN FOR THE THEME STUDY:

1. The main principles of the cell theory of Schwann and Schleiden. The development of the cell theory in the works of R. Virchow. The modern state of the cell theory.
2. The types of cell organization. Prokaryotic cells, their structure and typical features.
3. Eukaryotic cells, structural organization. The main organelles of eukaryotic cell, their role in the vital functions of the cell.
4. The structural and functional organization of cell membrane and its functions.
5. The cytoplasm, its membranous system and functions (endoplasmic reticulum, Golgy apparatus, lysosomes, ribosomes).
6. The organelles of metabolism, their structure and functions (mitochondria, chloroplasts).
7. The elements of cytoskeleton (microtubules, microfilaments, cell center).
8. Functional connection of cell organelles.
9. Morphological features of plant cells.

IV. THE QUESTIONS FOR SELF-CONTROL:

1. The history of discovery of the cell and the development of ideas about its structure (discovery of nucleus, cytoplasm).
2. The modern state of the cell theory, its significance for the development of materialistic ideas about the unit of organic world.
3. The types of cell organization. Hypotheses of origin of eukaryotes.
4. The typical features of prokaryotic cells.
5. The typical features of eukaryotic cells.
6. Structural and functional organization of cell membrane.
7. Endoplasmic reticulum, structure and functions.
8. Golgi apparatus, structure and functions.
9. Lysosomes, their structure and functions.
10. Mitochondria and chloroplasts, their structure and biological role.
11. Ribosomes, microtubules, microfilaments, centrioles, their structure and functions.
12. Functional connection of cell organelles as a base of cell system organization.
13. Morphological features of plant cells.
14. Cell inclusions, their significance.

V. INDEPENDENT WORK IN THE LABORATORY.
LABORATORY WORKS.

Study of onion film cells (x280).

- 1) Take the dry and clean glass slide.
- 2) Put the onion film on the glass slide.
- 3) Add the drop of water.

- 4) Cover the preparation by cover-slip and examine under low power magnification.
- 5) Find the onion film cells. Put 3-4 cells in the center of vision field.
- 6) Look for the object under high power magnification. Notice the cell wall, form and position of nucleus and number of nucleoli.
- 7) Draw the 3-4 cells under high power magnification and label:
 - 1 - cell wall;
 - 2 - cytoplasm;
 - 3 - nucleus;
 - 4 - nucleoli.

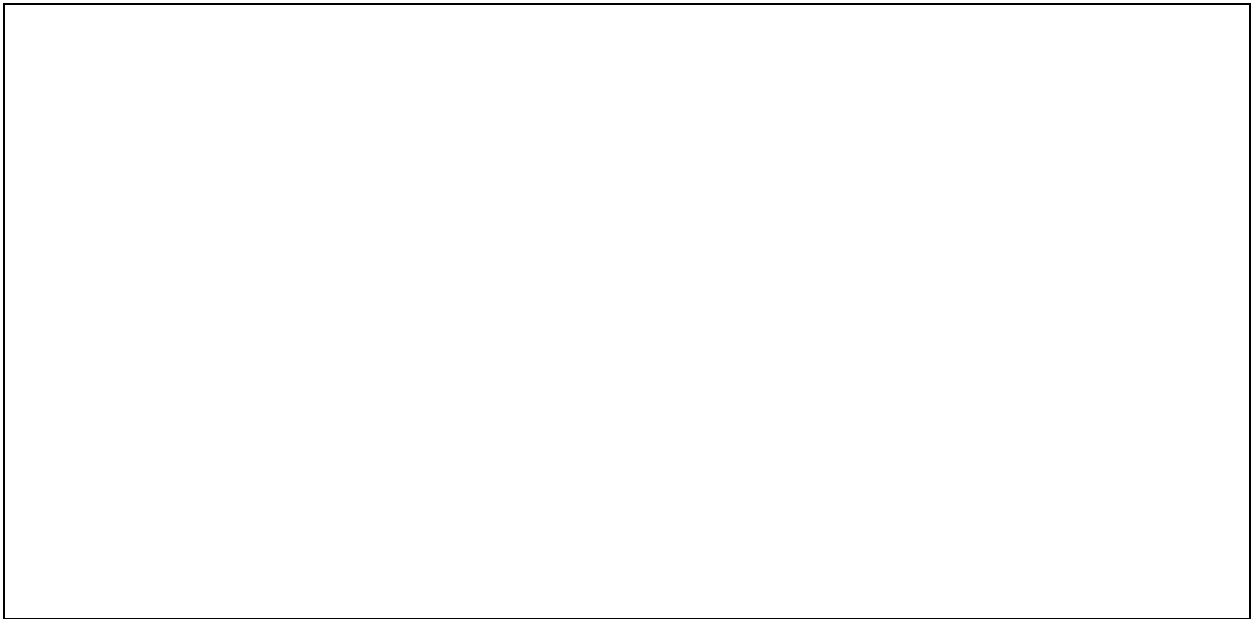

VI. HOMEWORK: Organization of hereditary material in pro- end eukaryotes. Hereditary apparatus of human cell.

PRACTICAL CLASS №3
ORGANIZATION OF HEREDITARY MATERIAL IN PRO- AND EUKARYOTES.
HEREDITARY APPARATUS OF HUMAN CELL

COMPETENCES:

GC-5, GPC-1.

I. THE AIM:

1. To study the peculiarities of structural organization of hereditary material in pro- and eukaryotes.
2. To study the structure of nucleus in eukaryotes.
3. To study the main features of organization of hereditary material in human cells.

II. THE BASIC KNOWLEDGE:

1. The typical features of morphological organization of pro- and eukaryotic cells.
2. An idea about chemical structure and biological properties of DNA.
3. The molecular bases of organization of hereditary material in pro- and eukaryotes.

III. THE PLAN FOR THE THEME STUDY:

1. Nucleic acids (DNA, RNA). Structure and functions in the cell. The structure of DNA and RNA nucleotides and their types.
2. Mechanism of DNA replication.
3. Gene as elementary unit of heredity.
4. Nucleus as information center of eukaryotic cells. The main components of nucleus.

IV. THE QUESTIONS FOR SELF-CONTROL.

1. Hereditary material and its properties.
2. The chemical composition of nucleic acids. The structure of DNA and RNA nucleotides and their types.
3. The bonds between nucleotides in polynucleotide chain of DNA and RNA molecule.
4. The joining of DNA strands in double helix.
5. Functions of DNA and RNA in the cell.
6. The mechanism of DNA replication.
7. Gene as an elementary unit of heredity.
8. Nucleus as information center of eukaryotic cell.

V. INDEPENDENT PRACTICAL WORK.

Study of DNA structure.

- 1) Take parts of nucleotides from the envelope and compose the piece of DNA molecule.
- 2) Draw the scheme of DNA molecule in the album.

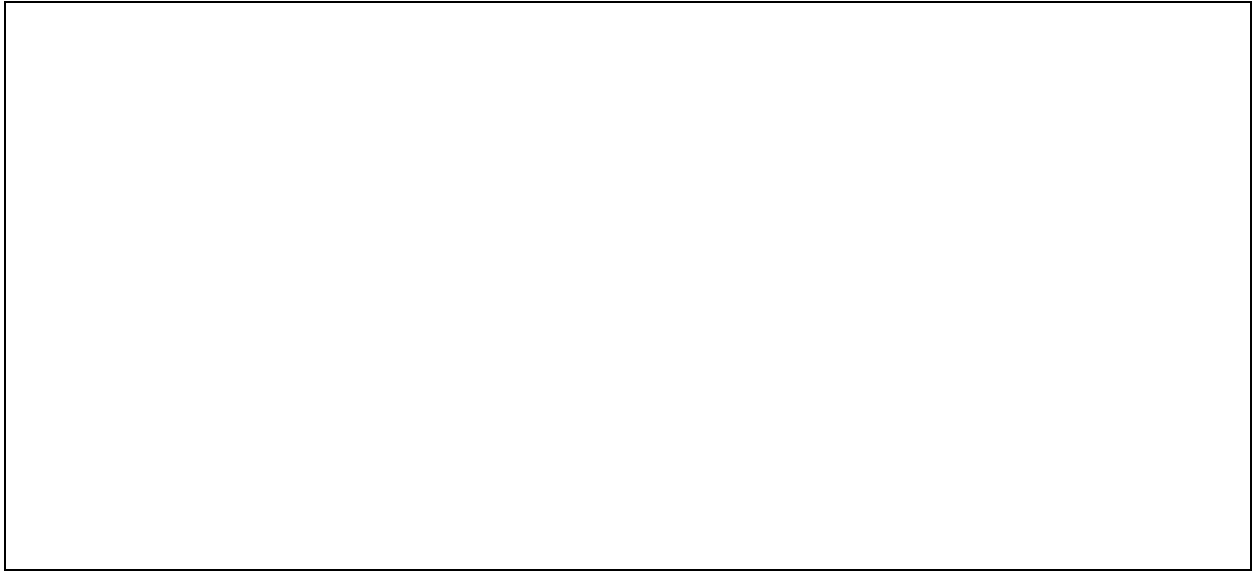

VI. SOLUTION OF THE PROBLEMS IN MOLECULAR BIOLOGY.

Problem 1. The strand of DNA molecule has the following sequence of nucleotides:

3'TATGTTGAACTTCGAAAG5'. Determine the sequence of nucleotides in the second strand of DNA.

Problem 2. The double helix of DNA has 22% of nucleotides with adenine (A). Determine the percentage of guanine (G), cytosine (C) and thymine (T) in this molecule.

VII. HOMEWORK: Realization of biological information in cell.

PRACTICAL CLASS №4
REALIZATION OF BIOLOGICAL INFORMATION IN CELL

COMPETENCES:
GC-5, GPC-1.

I. THE AIM:

1. To study the stages of protein biosynthesis.
2. To have knowledge about principles of regulation of gene activity in pro- and eukaryotes.

II. THE BASIC KNOWLEDGE:

1. The typical features of gene structure.
2. The structure of proteins and nucleic acids.

III. THE PLAN FOR THE THEME STUDY:

1. Definition of “gene” and its properties.
2. Genetic code and its properties.
3. Protein biosynthesis as the process of realization of biological information in the cell.
4. The main stages in the protein synthesis: transcription, translation, and their mechanisms.
5. Operon, its organization and principles of functioning.
6. Transcripton. Genes: promoters, operators, regulators, their characteristics.
7. Phenomenon of processing and splicing.
8. Gene expression and its regulation (induction and repression).

IV. THE QUESTIONS FOR SELF-CONTROL.

1. The definition of gene.
2. The properties of gene.
3. The functions of gene.
4. Structural organization of eukaryotic gene (Transcripton).
5. Genetic code.
6. The main properties of genetic code.
7. The main stages of protein synthesis: transcription, translation, and their biological significance.
8. The mechanism of transcription.
9. Processing.
10. Phenomenon of splicing.
11. Translation, its stages and mechanisms.
12. Organization of protein molecules.

V. SOLUTION OF THE PROBLEMS IN MOLECULAR BIOLOGY.

	U	C	A	G	
U	Phe Phe Leu Leu	Ser Ser Ser Ser	Tyr Tyr STOP STOP	Cys Cys STOP Trp	U C A G
C	Leu Leu Leu Leu	Pro Pro Pro Pro	His His Gln Gln	Arg Arg Arg Arg	U C A G
A	Ile Ile Ile Met	Thr Thr Thr Thr	Asn Asn Lys Lys	Ser Ser Arg Arg	U C A G
G	Val Val Val Val	Ala Ala Ala Ala	Asp Asp Glu Glu	Gly Gly Gly Gly	U C A G

Problem 1. The strand of DNA molecule has the following sequence of nucleotides: 3'TATGTTGAACTTCGAAAGTAA5'. Determine the structure of protein molecule, encoding this region of DNA molecule.

Problem 2. The hormone of pancreas, glucagon, consists of 29-th amino acids. The first 8 amino acids have the following sequence: his - ser - glu - gly - thr - phe - thr - ser. Determine the sequence of nucleotides in DNA molecule.

Problem 3. What is the molecular mass of gene, if one strand of DNA molecule encodes the polypeptide molecule with molecular mass 1500? Molecular mass of one amino acid is 100, molecular mass of one nucleotide is 345.

Problem 4. Complete the table, reading from the left to the right.

C												DNA double helix
						G	A					
	C	A				U						m-RNA
									G	C	A	t-RNA
			Trp									Protein

VII. HOMEWORK: Cell cycle. Mitosis. Meiosis.

PRACTICAL CLASS №5 CHROMOSOMAL INHERITANCE

COMPETENCES:
GC-5, GPC-1.

I. THE AIM:

1. To study the chromosomes and DNA Packaging.
2. To study the classification of chromosomes

II. THE BASIC KNOWLEDGE:

1. The chemical structure of chromosome.
2. The structure of proteins and nucleic acids.

III. THE PLAN FOR THE THEME STUDY:

1. Nucleus as information center of eukaryotic cells. The main components of nucleus.
2. Levels of chromatin packing in eukaryotes and their characteristics. Heterochromatin and euchromatin.
3. Morphological structure of metaphase chromosome.
4. Morphological types of chromosomes.
5. Karyotype. Human karyotype. Denver classification of human chromosomes.

IV. THE QUESTIONS FOR SELF-CONTROL.

1. Nucleus as information center of eukaryotic cell.
2. Structure and functions of nuclear envelope and nucleolus.
3. Chromatin, structure and functions. Heterochromatin and euchromatin.
4. Levels of chromatin packing in eukaryotes and their characteristics.
5. Morphological structure of metaphase chromosome.
6. Morphological types of chromosomes.
7. Definition of karyotype. Human karyotype.
8. Cytogenetic method of studying heredity
9. Denver classification of human chromosomes.
10. Chromosomal Mutations. Characteristics of Structural Chromosomal Mutations. Classification. Examples
11. Characteristics of Chromosomal number Mutations. Classification. Examples.

V. INDEPENDENT PRACTICAL WORK.

Cytogenetic method of studying heredity

This method involves conducting research, consisting of three main phases:

- isolating and culturing the cells, which will be analyzed (blood lymphocytes, bone marrow cells, chorionic cells, fetal blood cells, amniotic fluid cells);
- staining;
- a thorough analysis of the preparation under the microscope.

Cytogenetic methods helps in:

- 1) Studying the karyotypes of an organisms;
- 2) Making more precise the human number of chromosomal sets, number of chromosomes and morphology of separate chromosomes for diagnosing the chromosomal diseases;
- 3) Making up the genetic cards of chromosomes;
- 4) Studying the genome and chromosomal mutations.

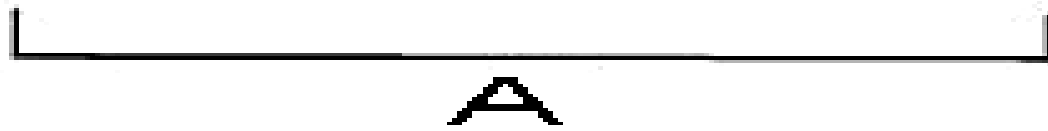

Karyotype:

chromosomal diseases:

PRACTICAL CLASS №6 CELL CYCLE. MITOSIS.

COMPETENCES:

GC-5, GPC-1.

I. THE AIM:

1. To study the natural laws of cell cycle.
2. To acquire the knowledge to determine the stage of mitosis in plant and animal cells.

II. THE BASIC KNOWLEDGE:

1. The morphological and functional organization of the cell.
2. An idea about DNA replication and organization of hereditary material in chromosomes.

III. THE PLAN FOR THE THEME STUDY:

1. Cell as a self-reproducing system. Cell cycle, its division into periods.
3. Mitotic cycle, its division into periods. Interphase, its stages and their biological role.
4. Characteristics of mitotic stages. Cytokinesis.
5. Significance of mitosis.
7. Changes of morphological and genetical chromosome structures during mitotic cycle.

IV. THE QUESTIONS FOR SELF-CONTROL.

1. Cell cycle, its division into periods.
2. Types of cell division.
3. Mitotic cycle.
4. Morphological description of stages of mitotic cycle.
5. Interphase, its stages and their biological role.
6. Characteristics of mitotic phases.
7. Genetic description of stages of mitotic cycle and mitotic phases.
8. The change of morphological and genetical structure of chromosomes during mitotic cycle.
9. The significance of morphological changes of chromosomes.
10. Cytokinesis.

V. INDEPENDENT PRACTICAL WORK.

Study of mitotic phases in the plant cells (x280; table).

- 1) Put the slide on the stage.
- 2) Find the division zone in onion rootlet under low power magnification. Put it in the center of field of vision.
- 3) Look for the object under high power magnification. Find the phases of mitosis: prophase, metaphase, anaphase, telophase and stage of interphase.
- 4) Draw the phases of mitosis and label:
interphase: 1 - nucleus; 2 - cytoplasm; 3 - chromatin;
prophase: 4 - chromosomes;
metaphase: 5 - metaphase plate;
anaphase: 6 - daughter chromosomes;
telophase: 7 - nuclei.

<i>interphase</i>	<i>prophase</i>	<i>metaphase</i>	<i>anaphase</i>	<i>telophase</i>

VI. HOMEWORK: Meiosis . Gametogenesis.

PRACTICAL CLASS №7
MEIOSIS. GAMETOGENESIS. BIOLOGY OF REPRODUCTION

COMPETENCES:

GC-5, GPC-1.

I. THE AIM:

1. To study the natural laws of cell division.
2. To acquire the knowledge to determine the stage of meiosis.
3. To study the types of reproduction of living organisms, and their biological mechanisms.

II. THE BASIC KNOWLEDGE:

1. The morphological and functional organization of the cell.
2. An idea about DNA replication and organization of hereditary material in chromosomes.
3. The mechanisms of reproduction and segregation of genetical material during mitosis.

III. THE PLAN FOR THE THEME STUDY:

1. Differences between mitosis in plant and animal cells.
2. Meiosis and its cytological and genetical mechanisms.
3. Changes of morphological and genetical chromosome structures during meiosis.
4. Biological role of meiosis.
5. Gametogenesis, its biological significance.
6. Spermatogenesis. Oogenesis.
7. Morphological features of spermatozoa and ova. Types of ova.
8. Reproduction and its biological role.
9. Evolution of reproduction. Types of reproduction.
10. Asexual reproduction, types, mechanisms and significance.
11. Sexual reproduction, types, mechanisms and significance.

IV. THE QUESTIONS FOR SELF-CONTROL.

1. Differences in mitosis between plant and animal cell.
2. Meiosis and its cytological and genetical mechanisms.
3. Biological role of meiosis.
4. Changes of morphological and genetical chromosome structures during meiosis.
5. Gametogenesis, its biological significance.
6. Spermatogenesis, stages and cytogenetic description.
7. Oogenesis, stages and cytogenetic description.
8. The peculiarities of spermatogenesis and oogenesis in human.
9. Morpho-functional organization of spermatozoa.
10. Morpho-functional organization of ova.
11. Reproduction and its biological role.
12. The types of reproduction.
13. The evolution of reproduction.
14. Asexual reproduction, types, mechanisms. Significance of asexual reproduction.
15. Sexual reproduction, types, mechanisms.
16. Significance of sexual reproduction.
17. The differences between asexual and sexual reproduction.

V. INDEPENDENT PRACTICAL WORK.

Work №1 Study of stages of meiotic division (table).

- 1) Using the table draw the first meiotic division. Pay attention to the longest and the most important prophase I stage of meiosis, its own stages, and the result of the first stage – two cells with haploid number of chromosomes (reduction division). Insert corresponding marks.

<i>Prophase I</i>	<i>Metaphase I</i>	<i>Anaphase I</i>	<i>Telophase I</i>
<i>number of chromosomes and DNA copies</i>			

2) Draw the stages of the second meiotic division. As the result – four cells with haploid number of chromosomes (gametes) genetically different from parents' cells (crossing over in prophase I).

<i>Prophase II</i>	<i>Metaphase II</i>	<i>Anaphase II</i>	<i>Telophase II</i>
<i>number of chromosomes and DNA copies</i>			

Work №2. Study of morphology of mammalian ovary (x63).

- 1) Put the slide on the stage.
- 2) Examine the structure of ovary under low power magnification. Notice the structure of follicle. Put it in the center of field of vision.
- 3) Draw the object
- 4) Take away the slide.

	1 - follicle; 2 - follicle cavity; 3 - ovule.
--	---

Work №3. Study of morphology of guinea-pig spermatozoa (x280).

- 1) Put the slide on the stage.
- 2) Examine the slide under low power magnification, find the spermatozoa and put it in the center of field of vision.
- 3) Look for the object under high power magnification. Study the structure of spermatozoa.
- 4) Draw the object and label:
- 5) Take away the slide.

	1 - head; 2 - neck; 3 - tail.
--	-------------------------------------

VI. HOMEWORK: prepare for the test.

PRACTICAL CLASS №8

MAJOR TEST IN CYTOLOGY

HOMEWORK: Individual development of organism. Embryonic development.

PRACTICAL CLASS №9
INDIVIDUAL DEVELOPMENT OF ORGANISM. EMBRYONIC DEVELOPMENT.
CLEAVAGE (BLASTULATION)

COMPETENCES:

GC-5, GPC-1, PC-1

I. THE AIM:

1. To study the periods and natural laws of ontogenesis.
2. To study the peculiarities of main periods of ontogenesis.
3. To acquire the knowledge to determine the periods of cleavage.

II. THE BASIC KNOWLEDGE:

1. The structural and functional organization of cell.
2. The types of reproduction of living organisms.
3. Morpho-functional organization of spermatozoa.
4. Morpho-functional organization of ova.

III. THE PLAN FOR THE THEME STUDY:

1. Definition and types of ontogenesis.
2. Division of ontogenesis into periods.
3. Embryogenesis, its biological role and main stages.
4. Cleavage, types. Blastula.

IV. THE QUESTIONS FOR SELF-CONTROL.

1. Definition of ontogenesis.
2. The types of ontogenesis.
3. Division of ontogenesis into periods.
4. Embryogenesis, its biological role and main stages.
5. Types of ova in vertebrates
6. Cleavage, its types.
7. Biological significance of cleavage.
8. Formation of blastula.
9. Morphology of blastula and types of blastula.

V. INDEPENDENT PRACTICAL WORK.

Work №1. Study of lancelet blastula (table).

Draw the object in the album and label:

1 - blastocoel; 2 - blastoderm; 3 - blastomeres.	
--	--

Work №2. Study of amphibians blastula (table).

Draw the object in the album and label:

1 - blastocoel; 2 – macromeres on vegetal pole 3. - micromeres on animal pole	
---	--

Work №3. Study of birds blastula (table).

Draw the object in the album and label:

1 - blastocoel; 2 - blastodisk 3 – yolk	
---	--

Work №3. Study of mammalian blastula (table).

Draw the object in the album and label:

1 - blastocoel; 2 – inner cell mass 3. - trophoblast	
--	--

VI. HOMEWORK: GASTRULATION. NEURULATION

PRACTICAL CLASS №10
INDIVIDUAL DEVELOPMENT OF ORGANISM. EMBRYONIC DEVELOPMENT.
GASTRULATION. NEURULATION.

COMPETENCES:

GC-5, GPC-1, PC-1

I. THE AIM:

1. To study the periods and natural laws of ontogenesis.
2. To study the peculiarities of main periods of ontogenesis.
3. To acquire the knowledge to determine the periods of gastrulation and organogenesis.

II. THE BASIC KNOWLEDGE:

1. The structural and functional organization of cell.
2. The types of reproduction of living organisms.
3. Types of ova in vertebrates
4. Cleavage, its types.
5. Morphology of blastula and types of blastula.

III. THE PLAN FOR THE THEME STUDY:

1. Gastrulation, types.
2. Neurulation.
3. Histo- and organogenesis.

IV. THE QUESTIONS FOR SELF-CONTROL.

1. Gastrulation, types of formation of gastrula, significance.
2. Morphology of gastrula.
3. Gastrulation in Amphioxus (lancelet)
4. Gastrulation in Amphibians
5. Gastrulation in Birds
6. Gastrulation in Mammals
7. Neurulation. Neurula.
8. The types of formation of mesoderm, its differentiation.
9. Histo- and organogenesis.
10. Molecular and genetic mechanisms of differentiation.

V. INDEPENDENT PRACTICAL WORK.

Work №1. Study of lancelet gastrula (table).

Draw the object in the album and label:

1 - ectoderm; 2 - entoderm; 3 - blastopore; 4 - gastrocoel.	
--	--

Work №2. Study of lancelet neurula (table).

Draw the object in the album and label:

1 - neural tube; 2 - ectoderm; 3 - endoderm; 4 - mesoderm; 5 - cavity of secondary intestine; 6 - chorda.	
--	--

VI. HOMEWORK: PROVISORY ORGANS OF VERTEBRATE EMBRYOS.

PRACTICAL CLASS №11
INDIVIDUAL DEVELOPMENT OF ORGANISM. EMBRYONIC DEVELOPMENT.
PROVISORY ORGANS OF VERTEBRATE EMBRYOS

COMPETENCES:
GC-5, GPC-1, PC-1

I. THE AIM:

1. To study the periods and natural laws of ontogenesis.
2. To study the peculiarities of main periods of ontogenesis.
3. To understand the role of provisory organs in ontogenesis.

II. THE BASIC KNOWLEDGE:

1. The structural and functional organization of cell.
5. Morphology of blastula and types of blastula.
1. Gastrulation, types.
2. Neurulation.

III. THE PLAN FOR THE THEME STUDY:

1. Provisory organs of vertebrate embryos.
2. The role of environment in development of organism. Critical periods of embryogenesis. Teratogenic factors.

IV. THE QUESTIONS FOR SELF-CONTROL.

1. Anamniotes and Amniotes.
2. Provisory organs of vertebrate embryos.
3. Yolk sac, its morphology and functions. Pathology of yolk sac (Meckel's diverticulum, umbilical vesicle, umbilical fistula).
4. Amnion, its morphology and functions. Pathology of amnion.
5. Allantois, its morphology and functions. Pathology of allantois.
6. Chorion, its morphology and functions. Pathology of chorion.
7. Critical periods of ontogenesis. Teratogenic factors.

V. INDEPENDENT PRACTICAL WORK.

Study of provisory organs in humans .

Draw the object in the album and label:

<ol style="list-style-type: none">1. Embryo2. Chorion3. Amnion4. Amniotic cavity5. Yolk sac6. Allantois7. Fetal part of placenta (chorion frondosum)8. Maternal part of placenta (decidua basalis)9. Chorionic villi	
--	--

VI. HOMEWORK: Major test in ontogenesis.

PRACTICAL CLASS №12

MAJOR TEST IN ONTOGENESIS.

HOMEWORK: RELATIONSHIP BETWEEN ONTOGENY AND PHYLOGENY.
EVOLUTION OF THE SKELETON AND SKIN OF VERTEBRATES.